



Point B  
Is Up to You.

# XE 290

The workhorse of the XE family, the XE 290 is a piston powered, water cooled, oil injected, fuel injected, 800 cc, electronic programmable ignition, 90HP experimental helicopter.

## FEATURES

- Rotor Head Built for 4X Centripetal Load
- 100% Composite Airframe Construction
- Dual High Capacity Belt Final Drive
- Cable Braced Aluminum Skids
- 62 lb. Monocoque Fuselage
- E-Glass in Vinyl Ester Matrix
- +/- 6G Airframe Stress Test
- Cog Belt Gear Reduction
- Vacuum Formed Canopy
- Tail Rotor Driveshaft
- Fast Build Assists
- Easy Maintenance
- Abundant Spare Parts
- Forum Community Support
- Low Cost Operation per Hour
- Dedicated Customer Following
- TBO Cost ~ \$18 / Hr @500 Hours
- Exceptional Autorotation Performance
- Detailed Instructions / Manuals / Videos

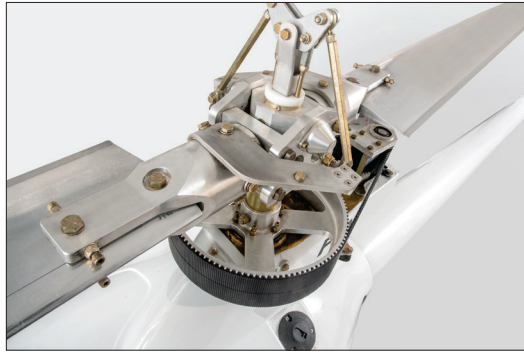

**Hundreds Made.  
Thousands of  
Airtime Hours.**

**STANDARD INSTRUMENTS**

- Rotor / Engine RPM
- Air Speed Indicator
- 4 Channel Temperature Indicator
- Tiny Tach Hour Meter

**OPTIONS**

- Factory Assist – 51% Compliant
- Factory Build – Export Only
- Factory Paint
- Large Dashboard Panel
- Gear Box Temperature Monitoring
- Vertical Tail Fin
- Vertical Tail Fin w/ Strobe
- Clear or Tint Doors
- Horizontal Wing
- Horizontal Wing w/ Winglets
- Position Lights
- S - Cyclic
- Military Style Grip for Cyclic
- Custom Pitot Tube
- Seat Cover
- Double Pad Seat Cover
- Ground Handling Wheel Kit
- Tinted Windscreen
- Collective Friction Lock
- Trim Tabs
- Trim Tab Lights
- Four Point Harness
- Radio / Antenna
- Transponder
- Custom Installations

**XE 290**

Max Air Speed  
Cruise Speed  
Climb Rate Estimated  
Estimated Flight Duration  
w/ Aux Tank  
Estimated Fuel Burn / Hour  
Fuel Capacity  
Fuel Cap w/ Aux Tank  
Empty Weight  
Max Gross (240 lb Pilot)  
Main Rotor @ 100%  
Tail Rotor @ 100%

**SPECIFICATIONS**

95 MPH / 152 Kph  
80 MPH / 128 Kph  
1200 FPM / 365 MPM  
1.8 Hours  
3.3 Hours  
6 GPH / 23 lph  
12 Gal / 45 Liters  
20 Gal / 76 Liters  
410 lb / 186Kg  
770 lb / 350 Kg  
600 RPM  
2720 RPM  
8000 ft / 2438 m  
10000 ft / 3048 m  
CFX800  
90 Shaft HP / 67 Kw  
2 Cylinder / 2 Stroke  
Mechanical Oil Injection  
EFI / Water Cooled  
93 Octane Pump Gasoline

**Engine**

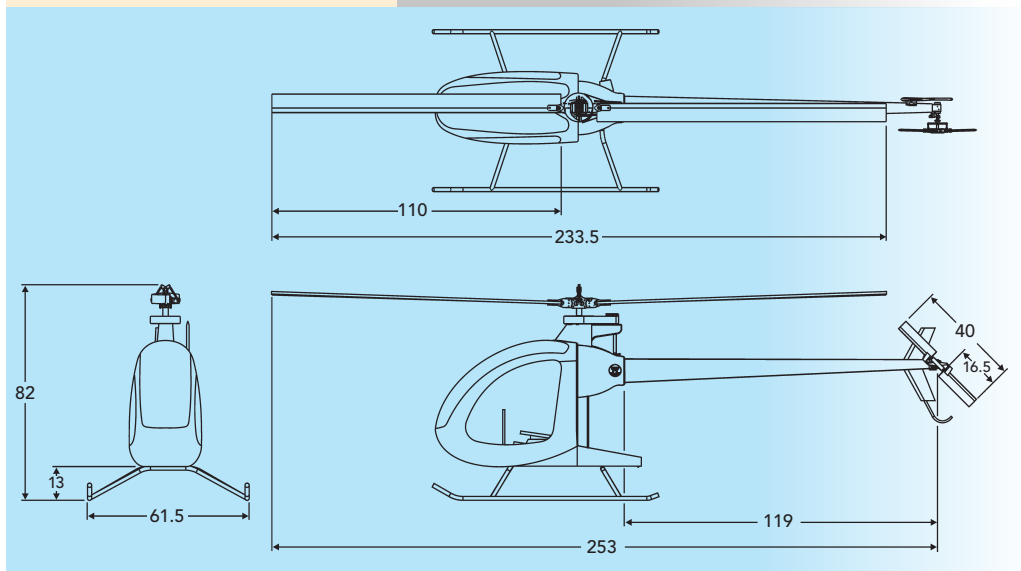

**Composite FX**

9069 SE CR 319  
Trenton, FL 32693 USA  
Tel 352.538.1624  
marketing@composite-fx.com