

You Can't  
Beat the View.

# XET

The flagship XET is  
powered by a modified  
T62-T2A1 Solar turbine  
engine, burning Jet A fuel  
and producing a very steady  
and powerful 95HP.

## FEATURES

- Rotor Head Built for 4X Centripetal Load
- 100% Composite Airframe Construction
- Dual High Capacity Belt Final Drive
- Cable Braced Aluminum Skids
- 62 lb. Monocoque Fuselage
- E-Glass in Vinyl Ester Matrix
- +/- 6G Airframe Stress Test
- Cog Belt Gear Reduction
- Vacuum Formed Canopy
- Tail Rotor Driveshaft
- Fast Build Assists
- Easy Maintenance
- Abundant Spare Parts
- Forum Community Support
- Low Cost Operation per Hour
- Dedicated Customer Following
- TBO Cost ~ \$18 / Hr @500 Hours
- Exceptional Autorotation Performance
- Detailed Instructions / Manuals / Videos

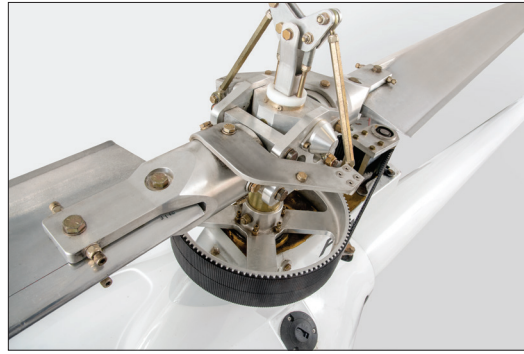

**Hundreds Made.  
Thousands of  
Airtime Hours.**

**STANDARD INSTRUMENTS**

- 8" Glass MGL Explorer Lite or Equivalent

**OPTIONS**

- Factory Build
- Factory Assist – 51% Compliant
- Factory Build – Export Only
- Large Dashboard Panel
- Gear Box Temp Monitoring
- Vertical Tail Fin
- Vertical Tail Fin w/ Strobe
- Clear or Tint Doors
- Horizontal Wing
- Horizontal Wing w/ Winglets
- Position Lights
- S - Cyclic
- Military Style Grip for Cyclic
- Custom Pitot Tube
- Seat Cover
- Double Pad Seat Cover
- Cargo Compartment
- Ground Handling Wheel Kit
- Auxiliary Fuel Tank 8 Gal
- Tinted Windscreen
- Collective Friction Lock
- Trim Tabs
- Trim Tab Lights
- Four Point Harness
- Radio / Antenna
- Transponder
- Custom Installations

**XET SPECIFICATIONS**

Max Air Speed	95 MPH / 152 Kph
Cruise Speed	80 MPH / 128 Kph
Climb Rate Estimated	1500 FPM / 457 MPM
Estimated Flight Duration w / Aux Tank	0.9 Hours
Estimated Fuel Burn / Hour	1.8 Hours
Fuel Capacity	10 GPH / 38 lph
Fuel Cap w / Aux Tank	12 Gal / 45 Liters
Empty Weight	20 Gal / 76 Liters
Max Gross [240 lb Pilot]	450 lb / 205Kg
Main Rotor @ 100%	850 lb / 386 Kg
Tail Rotor @ 100%	590 RPM
HOGE	2670 RPM
HIGE	10000 ft / 3048 m
Engine	12000 ft / 3658 m
	Solar T62-T2-A1
	95 Shaft HP / 71 Kw
	Radial Inflow Turbine
	10:1 Planetary Reduction
	Mechanical Fuel Control
	JET A Fuel

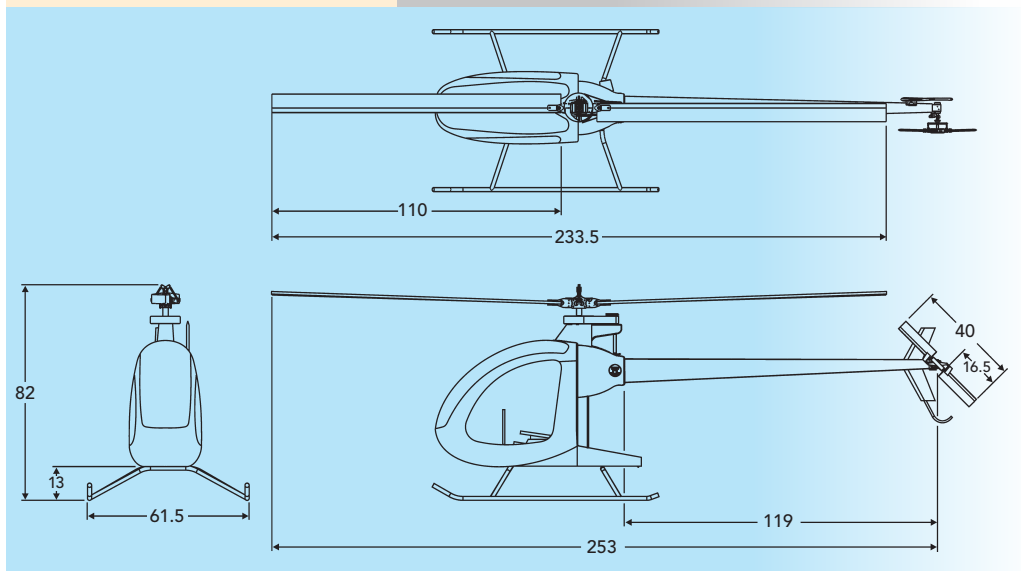

**Composite FX**  
9069 SE CR 319  
Trenton, FL 32693 USA  
Tel 352.538.1624  
marketing@composite-fx.com