



The Sky Is No Limit.

XE

The XE series is the industry standard of light helicopters. With exceptional auto-rotation capability and strong tail rotor authority, this machine performs as good as it looks.

FEATURES

- Rotor Head Built for 4X Centripetal Load
- 100% Composite Airframe Construction
- Dual High Capacity Belt Final Drive
- Cable Braced Aluminum Skids
- 62 lb. Monocoque Fuselage
- E-Glass in Vinyl Ester Matrix
- +/- 6G Airframe Stress Test
- Cog Belt Gear Reduction
- Vacuum Formed Canopy
- Tail Rotor Driveshaft
- Fast Build Assists
- Easy Maintenance
- Abundant Spare Parts
- Forum Community Support
- Low Cost Operation per Hour
- Dedicated Customer Following
- TBO Cost ~ \$18 / Hr @500 Hours
- Exceptional Autorotation Performance
- Detailed Instructions / Manuals / Videos

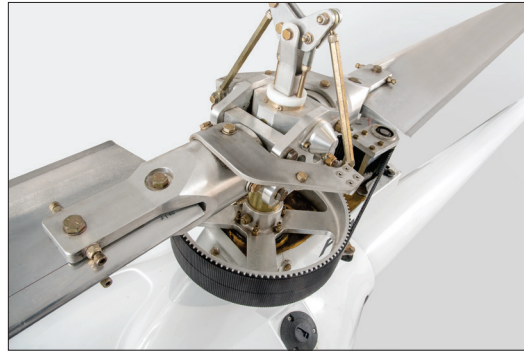

**Hundreds Made.
Thousands of
Airtime Hours.**

STANDARD INSTRUMENTS

- Rotor / Engine RPM
- Air Speed Indicator
- 4 Channel Temperature Indicator
- Tiny Tach Hour Meter

OPTIONS

- Factory Assist – 51% Compliant
- Factory Build – Export Only
- Factory Paint
- Large Dashboard Panel
- Gear Box Temperature Monitoring
- Vertical Tail Fin
- Vertical Tail Fin w/ Strobe
- Clear or Tint Doors
- Horizontal Wing
- Horizontal Wing w/ Winglets
- Position Lights
- S - Cyclic
- Military Style Grip for Cyclic
- Custom Pitot Tube
- Seat Cover
- Double Pad Seat Cover
- Ground Handling Wheel Kit
- Tinted Windscreen
- Collective Friction Lock
- Trim Tabs
- Trim Tab Lights
- Four Point Harness
- Radio / Antenna
- Transponder
- Custom Installations

XE SPECIFICATIONS

Max Air Speed	70 MPH / 112 Kph
Cruise Speed	65 MPH / 104 Kph
Climb Rate Estimated	900 FPM / 275 MPM
Estimated Flight Duration	1.8 Hours
Fuel Capacity	12 Gal / 45 Liters
Estimated Fuel Burn / Hour	6 GPH / 23 lph
Empty Weight	298 lb / 136Kg
Max Gross (240 lb Pilot)	610 lb / 275Kg
Main Rotor @ 100%	540 RPM
Tail Rotor @ 100%	2500 RPM
HOGE	6000 ft / 1829 m
HIGE	8000 ft / 2438 m
MZ202	
Engine	55 Shaft HP / 41 Kw
	2 Cylinder / 2 Stroke
	Air Cooled / Carbureted
	93 Octane Pump Gasoline
	50:1 Mix

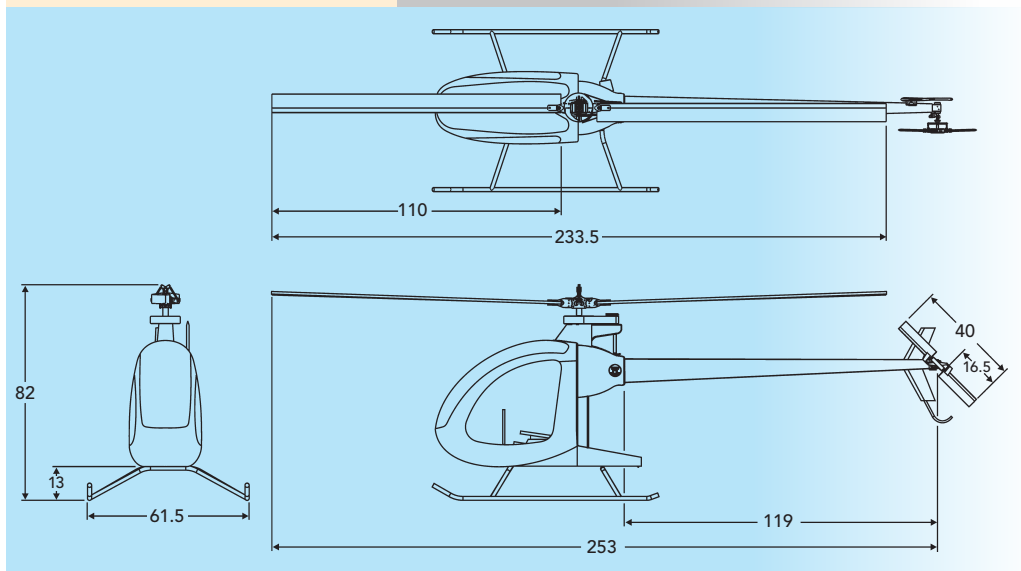

Composite FX
9069 SE CR 319
Trenton, FL 32693 USA
Tel 352.538.1624
marketing@composite-fx.com